

FLANGE ADAPTOR

03 Update - 06/2022

TECHNICAL DATA

Article No	001 117 5100 0450
d (mm)	450
d1 (mm)	465
d2 (mm)	545
d3 (mm)	442
le (mm)	195
L (mm)	66
Z (mm)	360
s (mm)	40,9
Weight (Kg)	20,630
Box Quantity (pcs)	1
Box Dimension (cm)	

INJECTION MOULDED

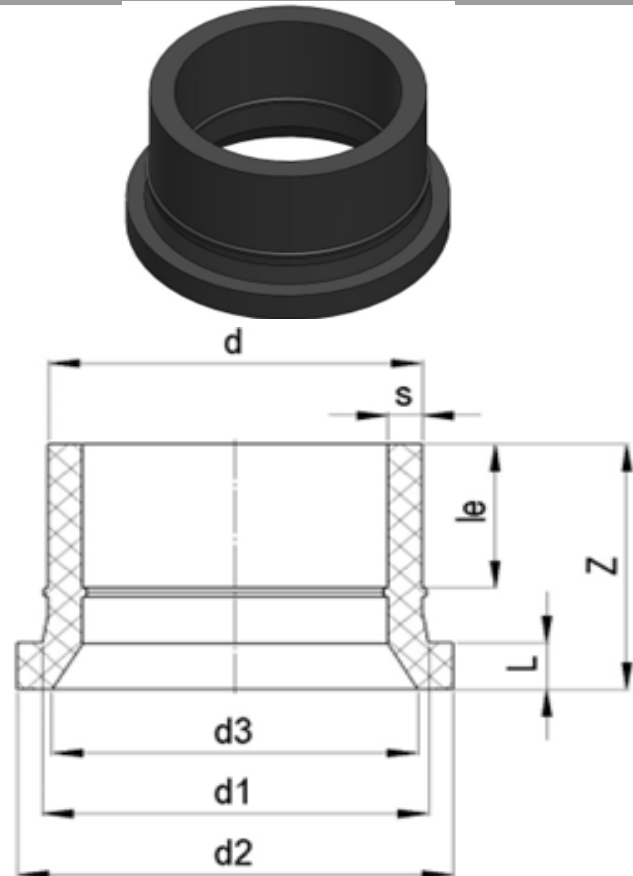

IDENTIFICATION OF PRODUCT

D(mm)	450(DN450)
SDR	11
RAW METARIAL	PE 100
PRESSURE CLASS	16 Bar Water
TRADEMARK	NTG
EXECUTION	Injection Moulded+Pipe Extended
STANDARD	EN 12201-3

SPECIFICATION

- Long Spigot
- Suitable for butterfly valve
- Chamfered finish, where d3 size is given
- Extended with PE100 Pipe
- Suitable for ansi flange

Tolerance on diameters and thickness according to the standards. The other dimensions are specialized. Tolerance $\pm 5\%$. NTG PLASTIK reserves all the right to change any information without giving prior notice. The production, distribution and utilization of this document without explicit authorization is prohibited.